

# General Practices & Procedures Reinforced Concrete Pipe



To properly understand the best method of sealing the joint of a precast concrete product, some of the myths and misconceptions about sealants must be discussed. Laboratory testing and engineering analysis has lead to some "rules of thumb" when selecting and applying precast concrete joint sealants in a compression joint – in this case for fuel containment, compression joints.

## Definitions

**Compression Joint:** A surface between two mating concrete sections where force is to be applied to compress the sealant material.

**Preformed sealant:** A composition of rubbers manufactured to meet a specific standard and formed into a shape for application in a compression joint.

**Hydrostatic:** Hydrostatic pressure is the pressure exerted by a fluid at equilibrium due to the force of gravity.

**Annular Space:** The intentional void space within a joint between the parallel angled surfaces.

**Spigot:** The part of the joint surface that extends out of the joint, the male end.

**Bell:** The part of the joint surface that is inside the joint, the female end.

**Butyl:** A hydrocarbon radical.

## Sealant Selection

### Materials

Sealants are typically designed to resist hydrostatic forces at a precast concrete joint to provide a watertight seal. The American Society of Testing and Materials (ASTM) specification C990 defines the required composition and performance testing requirements for preformed butyl sealants. Sealants that meet this standard will provide a reasonable level of assurance for performance in watertight requirements. Butyl rubber content and hydrocarbon content are synonymous terms.

ASTM C443 specifies a performance requirement, which exceeds ASTM C990. Concrete Sealants manufactures precast concrete joint sealants meeting or exceed these performance requirements. The shape, size/volume, and placement are critical for the performance of a watertight pipe joint in hydrostatic conditions.

### Shape

A traditional misconception of preformed sealants is that wider is better. That is a myth. Preformed butyl rubber sealants work best at higher rates of compression. As the sealant is compressed, the resistance force for further compression increases as a function of the percentage of compression. Time and temperature, as well as the sealant composition, will affect this rate. For instance, the force (psi) to compress the sealant the initial 10% to 50% may range from 2psi to 4psi. But as the sealant reaches 75% compression, the resistance force is about 8psi, and at 85% compression, this reaches a force of about 12psi. As the sealant is compressed, the sealing gasket increases in width as it becomes thinner. This width increases the surface area of the applied force. As the area reaches a point of equilibrium with the designed resistance force of the sealant, compression will stop. The analogy best used is the use of snow shoes. As the area of the applied force is increased, the force per square inch is reduced; thus enabling a person to walk on top of the snow.

*Don't Just Seal It, ConSeal It!*

© 2018 Concrete Sealants, Inc.

**Concrete Sealants, Inc.** 9325 State Route 201 ■ Tipp City, OH 45371 ■ **Toll Free** 800.332.7325

**P.** 937.845.8776 **F.** 937.845.3587 ■ **www.conseal.com**



Concrete Sealants, Inc.  
ISO 9001:2015 Registered

# General Practices & Procedures Reinforced Concrete Pipe



## Size / Volume

How much sealant is needed to seal the joint? The answer is as varied as the types and sizes of concrete castings being produced. There is no magic answer. Too little sealant may cause the joint to leak; too much sealant will be difficult to compress. The size of sealant required is determined by the volume needed to fill enough of the void to eliminate the possibility that a hydrostatic force will "push" the sealant. A minimum gasket width in the joint of 2" is common.

Sealant manufacturers will specify the minimum amount of compression that is necessary to assure a watertight seal. The quick answer is a minimum of 50% compression. However, a gap that is too large will not provide an adequate seal, even if the sealant is compressed by 50% of its height. ConSeal recommends a maximum joint gap of 3/8". This recommendation is good to follow for all joints of precast components. The important thing to remember is that the tighter the joint is, the better the seal is, and the less chance there is of a leak.

A rule of thumb for finding the width after compression is to use this formula:  $(TF/P)/100$ , where TF=Total force applied in pounds, P=the length of the entire perimeter in feet. Example: 15,000 pounds of force is applied to a rectangular casting 10' x 5'. The perimeter is 30 feet. Calculate:  $(15,000/30)/100=5$ . Therefore, the sealant will compress to a nominal width of about 5".

## Placement

Sealant placement is critical in providing the best, watertight joint. **Best practice is to place sealant where the concrete touches tightest; it is also preferred to fill the annular space.** On most reinforced concrete pipe sections, the best practice is to place the sealant on the outside of the spigot end near the tip. (See figure 1)

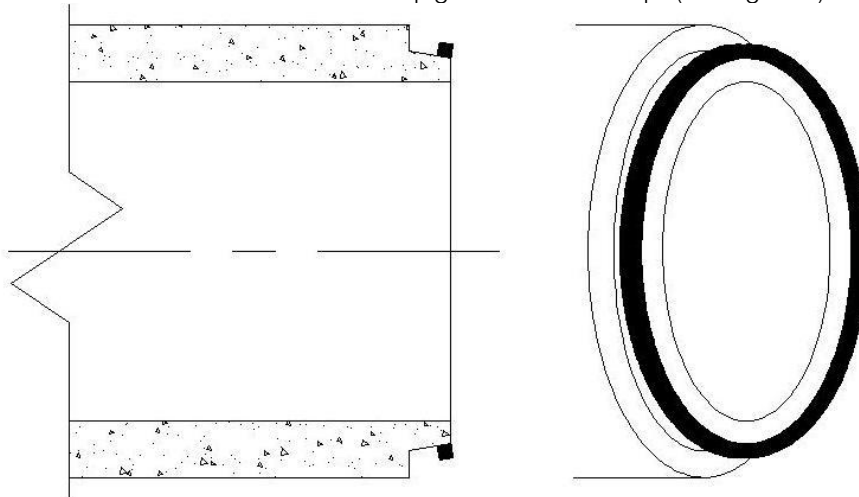

Figure 1

## Adhesion

The adhesion of the sealant to the concrete affects the hydrostatic resistance. Water can pass by sealant through the concrete by absorption if the joint surface is not properly prepared. This will result in wetness in or near the joint, opposite of the side of the joint where water is present. Sealant will adhere to a clean, dense, well-cured concrete surface. To improve adhesion, use one of ConSeal's primers to create a surface to adhere the sealant.

**Disclaimer:** This publication is to assist users to understand the proper use of ConSeal's products. *Contact ConSeal's technical staff for practices and procedures that meet your specific requirement.* Concrete Sealants, Inc. does not warranty any improper use of its products.

*Don't Just Seal It, ConSeal It!*

© 2018 Concrete Sealants, Inc.

**Concrete Sealants, Inc.** 9325 State Route 201 ■ Tipp City, OH 45371 ■ Toll Free 800.332.7325

**P.** 937.845.8776 **F.** 937.845.3587 ■ [www.conseal.com](http://www.conseal.com)



Concrete Sealants, Inc.  
ISO 9001:2015 Registered